

ViaCAD

Technology that thinks, as you draw

Product Overview

A Great Value

ViaCAD has more powerful features than many competitive CAD packages costing much more. Regardless of your experience, the convenience of these features are obvious right from the start.

Ease of Use

Simple interface and tools yield impressive, professional results. Use the patent pending 2D/3D user interface to work comfortably in 2D. Switch at any time to 3D to add depth and features if you choose. Innovative LogiCursor™ technology aids in visually anticipating your moves, assisting throughout the design process whether you are designing in 2D or 3D.

Precise Modeling

ViaCAD is a precise software application that provides state of the art modeling tools without sacrificing speed and ease of use. Use ViaCAD to explore and develop new product concepts using a variety of modeling methods including curves, surfaces, and solids all seamlessly integrated into a user friendly design environment.

Versatile, Intelligent Modeling Methods

ViaCAD supports an integrated collection of 2D, 3D, surface, and solid modeling tools. You choose the tools or combination of tools you need for the task at hand. The different construction methods work together with transparent associativity and a history tree to provide rapid design modifications.

State of Art Modeling Tools

ViaCAD is not your typical widget based modeler found in the Mechanical CAD communities. ViaCAD was designed from the ground up to make complex shapes using a variety of modeling practices. Designers can choose from a variety of integrated design methods that include:

- Curves (Points, Lines, Splines, Arcs, Ellipses, Conics)
- Surfaces
- Solids (Primitives, Profile Based, Surface Based, Features)
- Features (Fillet, Chamfer, Shell, Boss, Holes, Protrude, Cutout)
- Local *Face* (Modify foreign parts without history)
- Warp (Bend, twist, stretch NURB bodies independent of history)

Seamless sharing with other applications

ViaCAD shares data with AutoCAD™ and Adobe Illustrator™. However, unlike faceted based packages, ViaCAD uses a precise kernel that shares data using SAT, IGES, STEP, and DXF/DWG.

Have More Fun Designing

Casual, hobby, or professional use, ViaCAD's productivity makes your project more enjoyable right from the start.

Beginner or expert, ViaCAD combines intuitive tools with precision features creating professional results. ViaCAD's innovative visual interface provides feedback and works with you through out the design process, enhancing your creativity.

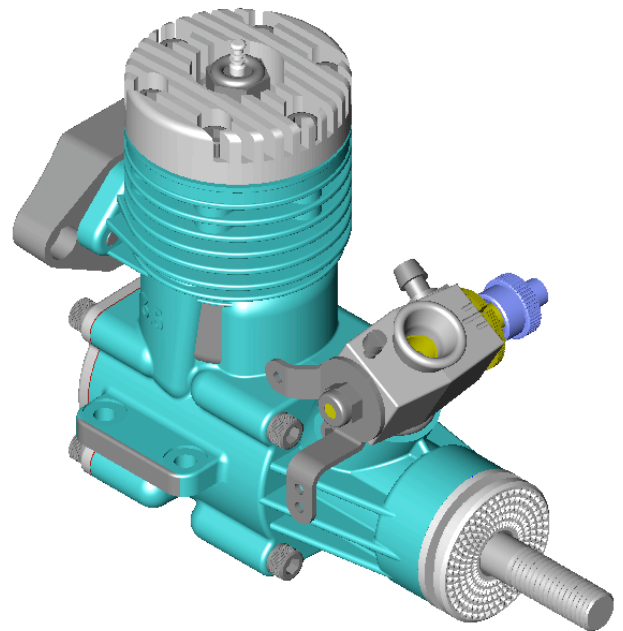

punch!
SOFTWARE®
www.punchsoftware.com

©2006 Punch! Software Inc. All Rights Reserved.

Technical Features 2D

Usability

- Easily switch between 2D or 2D/3D user interface.
- Same intuitive user interface for 2D and 3D tools
- Concept Explorer to examine and modify associative relationships and construction history
- Customizable key short cuts
- Prompt Window for prompting designer through commands
- Data Entry Window for explicit creation and modification of geometry.
- Object Info Window
- Tool Tips and Hints
- Tool Help
- Tool Cursors
- Multiple Monitor Savvy
- Customize background and foreground colors
- Small or large tool palette option
- User defined views, work planes, and pen styles
- Unlimited Undo and Redo
- User Defined Working Units
 - Inches
 - Feet
 - Feet/Inches
 - Millimeter
 - Meters

LogiCursor™

- Snaps for intelligently locating x y z drawing positions
- Mid Points, End Points
- Centers
- Intersections (Real and Extended)
- Dynamic Axis Locking
- Along Axis Alignments
- Snap Filters
- Tangents and Perpendiculars
- Works in 3D and 2D

Data Management

- Layers and Sub Layers
- Isolate Layer
- Increment/Decrement Layer
- Layer Locking
- Layer Color Override
- Object show/hide tools
- Automated File Backups
- Group and Ungroup
- Lock and UnLock

Viewing

- Standard Top, Bottom, Front, Side, Back, Isometric, Trimetric Views
- User defined views
- Zoom In/Zoom Out
- Zoom Previous
- Zoom All
- Zoom Window
- Zoom Home
- Zoom Ratio

- Zoom to Scale
- Zoom to Selected
- Wheel Button Zoom
- Wheel Button Rotate
- Space Bar Panning
- 3D Connexion Support

2D Creation

- Point Tools
 - Point at location
 - Point along curve
 - Point across surface
- Line Tools
 - Line Two Points, Connected
 - Midpoint
 - Parallel
 - Double Line
 - Construction Line
- Arc Tools
 - Start, End, On
 - Center Point, Start, End
 - Start, On, End
 - Start, Tangent, End
- Circle Tools
 - Start, On, End
 - Opposite Points
 - Center, On
 - Tangent 3 Curves
 - Tangent 2 Curves
- Conic Tools
 - 2 Point Start, End
 - 3 Point (Start, End, Slope, Rho)
 - 4 Point (Start, End, Slope, On)
- Ellipse Tools
 - Center, Diagonal
 - Two Diagonals
 - Opposite Points
 - Center 3 Points
 - Major Axis 3 Points
- Polygon Tools
 - Rectangle
 - Inscribed
 - Circumscribed
 - Arbitrary Points
 - From Curves
- Spline Tools
 - Fit Through Points
 - Control Polygon
 - Bezier
 - Sketch
 - On Surface
 - Add/Remove Point
 - Smooth
 - Elevate
 - Modify/Set Slope
 - Change Type

2D Editing & Utilities

- Dynamic modification of positions and tangencies
- Fillet
 - Fillet Two Curves
 - Fillet Three Curves
- Spline Fill
- Chamfering

- Chamfer by Length
- Chamfer by Angle
- Corner

- Trim, Extend, Segment
- Region Trim
- Divide, Break At
- Connect, Join
- Offset By Value or To Location
- Transformations
 - Translate, Rotate, Mirror
 - Scale (and Non Uniform)
 - Linear Duplicate
 - Polar Duplicate
 - Translate Along Path
 - Align, Stretch, Twist
- Verify
 - 2 Point Distance & Angles
 - Minimum Distance
 - Curve Lengths
 - 2D Planar Properties (Area, Centroid, Principle Moments)
 - Dynamic Curvature Plots

Annotation/Detailing

- Pen Weights, Patterns, Styles
- Dimension Tools
 - Smart Dimensions
 - Horizontal, Vertical, Parallel
 - Chain & Baseline
 - Ordinates
 - Radial & Diameter
 - Center Marks
 - Leaders and Callouts
 - Angular
 - Tolerances & User Settings
 - Stacked, Dual, Fractions
- Hatching
 - Iso and Din Standards
 - Metal and Mineral Categories
 - Custom Angles and Spacing
- Fill Patterns
 - Solid color fills
 - Patterned fills
- Bill of Materials
 - Export comma delimited file
 - Automatic table creation
 - Automatic balloons for labeling
- Text Tools
 - Horizontal
 - At Angle
 - Within Box
 - Along Curve

Automated 3D to 2D

- Generate 2D drawings automatically from 3D models
- Scalable Draw Views
- Section Views
- Detail Views
- Auxiliary Views
- Predefined Drawing Templates

Precision Kernel

- Precise ACIS kernel from Spatial serves as foundation for NURB and analytic based geometry definitions

Technical Features 3D

Verification Tools

- 2 Point Distance & Angles
- Lengths & Minimum Distance
- Interference Detection
- 2D Planar Properties (Area, Centroid, Principle Moments)
- Dynamic Curvature Plots

Lighting

- Ambient
- Distant
- Point
- Spot

Surfacing Modeling

- Infinite Plane
 - X,Y,Z Axis Aligned
 - Normal plus location
 - By three points
 - Along a curve
- Nets (MxN curve networks)
- Skin Surface
 - Draft angles and magnitude
 - Perpendicular take offs
 - Simplify Option
- Ruled Surface
- Cover Surface
 - Planar and Non Planar
 - N-Sided Edges
- Revolve Surface
 - 2 Pt Revolve
 - About curve revolve
- Extrude by Vector
- One Rail Sweep
 - In place sweeping
 - Perpendicular sweeping
- Two Rail Sweep
 - Maintain height option
- Tube/Pipe Surface
- Thicken Surface to Solid
- Associativity for rapid design modifications

Surface Utilities

- Plane/Surface Intersection
- Project Curve to Surface
 - Imprint Option
- Surface/Surface Intersection
- Curve/Surface Intersection
- Silhouette Curve Calculation
 - From view or user vector
- Explode Surface Edge
- Project curve to plane
 - Workplane
 - XY, XZ, YZ Planes
 - Select Infinite Plane

Solid Modeling

- Solids from Primitives
 - Sphere
 - Block
 - Cylinder
 - Cone
 - Torus
 - Prism
 - Pyramid
 - Ellipsoid

- Slab
- Lathe Profile
- Extrude Profile
 - Vector
 - Distance
 - To Object
 - Mid plane
 - Thin extrude
- One Rail Sweep
 - Sweep in Place
 - Sweep Rigid
 - Sweep perpendicular
 - Sweep to Object
 - Twist and draft parameters
- Two Rail Sweep
 - Maintain Height Option
- Cutout from profile
- Protrusion from profile
 - Terminate at face
 - Terminate at distance
 - Terminate at body
 - Draft Angle Optional
- Solid from sections (Skin Solid)
- Pipe Solid
 - By inner/outer diameter
- Branched Solid
 - Up to five branches
- Associativity between curves and resultant solids for rapid design modifications.

Feature Operations

- Feature based modeling
- Parametric Features
- Feature/History Tree
- Shelling
 - Constant Wall Thickness
 - Editable multi wall thickness
 - Option to keep shelled core
- Holes
 - Simple
 - Counerbore
 - Counter sink
 - Through body, to face, to depth
- Bosses
- Shelling
- Constant Radius Blends
 - Vertex Blends
 - Elliptical Section Blends
 - Circular Section Blends
 - Multi-Edge Blending
- Variable Radius Blends
 - Linear Blends
 - By position
 - By curve map
 - Fixed Width Blends
- Constant Length Chamfers
 - One Length
 - Two Length
 - Length/Angle
 - Vertex
- Variable Length Chamfers
 - Two Lengths
 - Two Length Chamfer
 - Four Length Chamfer
 - Lengths and Angles

- By position
- Fixed width
- Bending
 - 2 Point bend axis
 - Center line bend
 - Bend angle and radius

Solid Modeling Utilities

- Boolean Operations
 - Add, Subtract, Intersect
- Trim
- Split
- Thicken
 - Thicken surface to solid
 - Thicken existing solid
 - Thin existing solid
- Stitching Surfaces to Solids
 - User defined tolerances
 - Healing & Repair
 - Tolerant Edges
 - NURB to Analytic Simplify

Local Face Editing

- Use local face tools to modify imported files which do not have history or feature parameters
- Draft Face
- Match Face
- Move Face
- Offset Face
- Remove Face
- Replace Face

Data Exchange

- SketchUp
- DXF/DWG
- ACIS SAT
- IGES & STEP
- Adobe Illustrator (V6)
- Rhino™ 3DM (Import Only)
- STL (ASCII and Binary)
- BMP
- PICT (Mac Only)
- CGM (Import Only)
- 3D Studio™ (Import Only)
- TurboCAD™ Mac
- TurboCAD™ Mac Pro

Part Library

- 30,000+ Part Library
- 2D and 3D Symbols
- Drag and Drop Parts
- Dynamically Position
 - Electrical
 - HVAC
 - Mechanical
 - Construction,
 - Posed Figures
 - LAN
 - CMOS
 - Doors, Windows
 - Kitchen Counters
 - Basic Home Design
 - Office Furniture
 - Kitchen Cabinets
 - Bathroom Counters